



Kraftfahrt-Bundesamt

DE-24932 Flensburg



MITTEILUNG

Ausgestellt von:

Kraftfahrt-Bundesamt

über die Genehmigung
für einen Schutzhelmtyp mit Visiertyp(en) nach der Regelung Nr. 22

COMMUNICATION

Issued by:

Kraftfahrt-Bundesamt

concerning approval granted
of a type of protective helmet with visor type(s) pursuant to Regulation No. 22

Nummer der Genehmigung: **E1*22R05/02*300696*00**
Approval No.

1. Fabrik- oder Handelsmarke:
Trade name or mark:
LS2, MHR, TAKAI
2. Typ:
Type:
OF573-1

Handelsbezeichnung(en):
General commercial description(s):
OF573, OF573-1, TWISTER
3. Größen:
Sizes:
XS(54), S(56), M(58), L(59), XL(60), XXL(61)
4. Name des Herstellers:
Manufacturer's name:
JIANGMEN PENGCHENG HELMETS LTD.
CN-Gonghe Town, Heshan City
5. Anschrift:
Address:
(s. 4.)



Kraftfahrt-Bundesamt

DE-24932 Flensburg

2

Nummer der Genehmigung: E1*22R05/02*300696*00

Approval No.:

6. Gegebenenfalls Name des Vertreters des Herstellers:
If applicable, name of manufacturer's representative:
entfällt
not applicable
7. Anschrift:
Address:
(s. 6.)
8. Kurze Beschreibung des Helms:
Brief description of helmet:
siehe Anlagen
see enclosures
9. Helm ohne Kinnbügel **(J)**
Helmet without lower face cover **(J)**
10. Visiertyp oder Visiertypen:
Type of visor or visors:
OF-MHR-88
E1 22R 05300600
11. Kurze Beschreibung des Visiers oder der Visiere:
Brief description of visor or visors:
siehe Anlagen
see enclosures
12. Zur Genehmigung vorlegt am:
Submitted for approval on:
03.07.2018
13. Technischer Dienst, der die Prüfungen für die Genehmigungen durchführt:
Technical service responsible for conducting approval tests:
SGS-TÜV Saar GmbH
DE-81379 München
14. Datum des Gutachtens des Technischen Dienstes:
Date of report issued by that service:
29.06.2018
15. Nummer des Gutachtens des Technischen Dienstes:
Number of report issued by that service:
HOM ECN T18/101-00
16. Bemerkungen:
Comments:
entfällt
not applicable
17. Die Genehmigung wird **erteilt**
Approval **granted**



Kraftfahrt-Bundesamt

DE-24932 Flensburg

3

Nummer der Genehmigung: E1*22R05/02*300696*00

Approval No.:

18. Ort: **DE-24932 Flensburg**
Place:

19. Datum: **16.07.2018**
Date:

20. Unterschrift: **Im Auftrag**
Signature:

(D. Stieglitz)



21. Folgende mit der oben erwähnten Genehmigungsnummer versehene Dokumente sind auf Anforderung erhältlich.
The following documents, bearing the approval number shown above, are available on request:

Nebenbestimmungen und Rechtsbehelfsbelehrung
Collateral clauses and instruction on right to appeal

1 Prüfbericht mit Anlagen
1 Test report with appendices

1 Beschreibungsmappe R22-OF573-1-00 (15 Blatt)
1 Information folder R22-OF573-1-00 (15 sheets)



Kraftfahrt-Bundesamt

DE-24932 Flensburg

Nr. der Genehmigung: E1*22R05/02*300696*00

Approval No.:

- Anlage -

Nebenbestimmungen und Rechtsbehelfsbelehrung

Nebenbestimmungen

Jede Einrichtung, die dem genehmigten Typ entspricht, ist gemäß der angewendeten Vorschrift zu kennzeichnen.

Das Genehmigungszeichen lautet wie folgt:



05300696/J -

Die Einzelerzeugnisse der reihenweisen Fertigung müssen mit den Genehmigungsunterlagen genau übereinstimmen. Änderungen an den Einzelerzeugnissen sind nur mit ausdrücklicher Zustimmung des Kraftfahrt-Bundesamtes gestattet.

Änderungen der Firmenbezeichnung, der Anschrift und der Fertigungsstätten sowie eines bei der Erteilung der Genehmigung benannten Zustellungsbevollmächtigten oder bevollmächtigten Vertreters sind dem Kraftfahrt-Bundesamt unverzüglich mitzuteilen.

Verstöße gegen diese Bestimmungen können zum Widerruf der Genehmigung führen und können überdies strafrechtlich verfolgt werden.

Die Genehmigung erlischt, wenn sie zurückgegeben oder entzogen wird, oder der genehmigte Typ den Rechtsvorschriften nicht mehr entspricht. Der Widerruf kann ausgesprochen werden, wenn die für die Erteilung und den Bestand der Genehmigung geforderten Voraussetzungen nicht mehr bestehen, wenn der Genehmigungsinhaber gegen die mit der Genehmigung verbundenen Pflichten – auch soweit sie sich aus den zu dieser Genehmigung zugeordneten besonderen Auflagen ergeben - verstößt oder wenn sich herausstellt, dass der genehmigte Typ den Erfordernissen der Verkehrssicherheit oder des Umweltschutzes nicht entspricht.

Das Kraftfahrt-Bundesamt kann jederzeit die ordnungsgemäße Ausübung der durch diese Genehmigung verliehenen Befugnisse, insbesondere die genehmigungsgerechte Fertigung sowie die Maßnahmen zur Übereinstimmung der Produktion, nachprüfen. Es kann zu diesem Zweck Proben entnehmen oder entnehmen lassen. Dem Kraftfahrt-Bundesamt und/oder seinen Beauftragten ist ungehinderter Zutritt zu Produktions- und Lagerstätten zu gewähren.

Die mit der Erteilung der Genehmigung verliehenen Befugnisse sind nicht übertragbar. Schutzrechte Dritter werden durch diese Genehmigung nicht berührt.

Rechtsbehelfsbelehrung

Gegen diese Genehmigung kann innerhalb eines Monats nach Bekanntgabe Widerspruch erhoben werden. Der Widerspruch ist beim **Kraftfahrt-Bundesamt, Fördestraße 16, DE-24944 Flensburg**, schriftlich oder zur Niederschrift einzulegen.



Kraftfahrt-Bundesamt

DE-24932 Flensburg

2

Nummer der Genehmigung: E1*22R05/02*300696*00

Approval No.:

- Attachment -

Collateral clauses and instruction on right to appeal

Collateral clauses

All equipment which corresponds to the approved type is to be identified according to the applied regulation.

The approval identification is as follows: - see German version -

The individual production of serial fabrication must be in exact accordance with the approval documents. Changes in the individual production are only allowed with express consent of the Kraftfahrt-Bundesamt.

Changes in the name of the company, the address and the manufacturing plant as well as one of the parties given the authority to delivery or authorised representative named when the approval was granted is to be immediately disclosed to the Kraftfahrt-Bundesamt.

Breach of this regulation can lead to recall of the approval and moreover can be legally prosecuted.

The approval expires if it is returned or withdrawn or if the type approved no longer complies with the legal requirements. The revocation can be made if the demanded requirements for issuance and the continuance of the approval no longer exist, if the holder of the approval violates the duties involved in the approval, also to the extent that they result from the assigned conditions to this approval, or if it is determined that the approved type does not comply with the requirements of traffic safety or environmental protection.

The Kraftfahrt-Bundesamt may check the proper exercise of the conferred authority taken from this approval at any time. In particular this means the compliant production as well as the measures for conformity of production. For this purpose samples can be taken or have taken. The employees or the representatives of the Kraftfahrt-Bundesamt may get unhindered access to the production and storage facilities.

The conferred authority contained with issuance of this approval is not transferable. Trade mark rights of third parties are not affected with this approval.

Instruction on right to appeal

This approval can be appealed within one month after notification. The appeal is to be filed in writing or as a transcript at the **Kraftfahrt-Bundesamt, Fördestraße 16, DE-24944 Flensburg.**

Technical Report

Test standard:
ECE Regulation No. 22

Level of amendment:
Supplement 2 to the 05 series of amendments

Title:
Protective helmets and their visors

Manufacturer:
Jiangmen Pengcheng Helmets Co., Ltd.

Type:
OF573-1

Subject of testing:
Component

0 General

0.1	Make (trade name of manufacturer):	LS2, MHR, TAKAI
0.2	Type:	OF573-1
0.2.1	Commercial description:	OF573, OF573-1, TWISTER
0.3	Means of identification of type, if marked on the vehicle:	n.a.
0.3.1	Location of that marking:	n.a.
0.4	Category of vehicle:	n.a.
0.5	Manufacturer's name and address:	Jiangmen Pengcheng Helmets Co., Ltd. Industrial Park East, Gonghe Town, Heshan City Guangdong Province, China
0.8	Address of assembly plant:	Jiangmen Pengcheng Helmets Co., Ltd. Industrial Park East, Gonghe Town, Heshan City Guangdong Province, China
0.9	Name and address of representative:	n.a.
	Location of the ECE approval mark:	refer to information document

1 Test record

See appendix

2 Attachments

2.1 List of modifications:

2.2 Information folder:

No.: R22-OF573-1-00

Date of issue: 01.06.2018

3 Statement of conformity

The information folder as mentioned under no. 2.2 and the type described therein are in compliance with the test standard mentioned above.

With regard to the required level of performance to be achieved, the test specimen were representative for the type to be approved.

The tests were carried out in accordance to the relevant requirements of the

EN ISO/IEC 17025:2005 EN ISO/IEC 17020:2012

**Test Laboratory
 SGS-TÜV Saar GmbH**

notified by

Kraftfahrt-Bundesamt (KBA),
 Federal Republic of Germany

National Standards
 Authority of Ireland (NSAI)

Rijksdienst voor het Wegverkeer
 (RDW),
 The Netherlands

No. KBA - P 00084 – 10

No. 101

No. 99050064 00

Responsible expert

Signature

Lell Wu

Jun 29, 2018



Conformity check

Signature

Doris Yang

Jul 3, 2018



This Technical Report shall be reproduced and published in full only and by the client only. It shall be reproduced partially with the written permission of the Test Laboratory only.

This document is issued by the Company subject to its General Conditions of Service (www.sgsgroup.de/agb). Attention is drawn to the limitations of liability, indemnification and jurisdictional issues established therein. This document is an original. If the document is submitted digitally, it is to be treated as an original within the meaning of UCP 600. Any holder of this document is advised that information contained hereon reflects the Company's findings at the time of its intervention only and within the limits of client's instructions, if any. The Company's sole responsibility is to its Client and this document does not exonerate parties to a transaction from exercising all their rights and obligations under the transaction documents. Any unauthorized alteration, forgery or falsification of the content or appearance of this document is unlawful and offenders may be prosecuted to the fullest extent of the law.

Test record

1 Test object and measuring equipment

1.1 Test object

- Protective helmet (without visor)
- Protective helmet (with visor)
- Visor

1.1.1 Protective Helmet

Type: OF573-1
 Sizes: XS(54), S(56), M(58), L(59), XL(60), XXL(61)
 Lower face cover: Without lower face cover (J)
 Protective (P)
 Non protective (NP)

1.1.2 Helmet visor

Visor type: OF-MHR-88
 Approval No.: E1 22R 05300600

1.1.3 Sun shade

The helmet is equipped with a swivel-mounted sun shade, which may only be used in combination with the visor in closed position according to the user manual

- On the inner side of the visor
- On the outer side of the visor
- Not applicable

1.1.4 Remarks:

n.a.

1.2 Equipments for measuring and testing:

1.2.1 Test equipment:

The equipment and the test facilities on which the tests were carried out fulfilled the requirements of the ECE Regulation 22.05

1.2.2 Measurement procedure:

according to ECE Regulation No. 22.05

2 Test Results

2.1 Protective helmet

2.1.1 Marking (clause 4.1.1, 4.4)

All required information, in accordance with the ECE R22.05, is given by the labels

- fulfilled
- Not fulfilled
- n.a.

2.1.2 Basic construction (clause 6.1)

Shell + Protective padding + Retention system

- fulfilled
- Not fulfilled
- n.a.

2.1.3 If fitted with non protective lower face cover (clause 6.2)

- Marked "Does not protect chin from impacts"
- Marked with symbol 
- n.a.

2.1.4 Extent of the protection (clauses 6.4, 6.5)

The shell and the protective padding cover all areas as required

- fulfilled
- Not fulfilled
- n.a.

2.1.5 Projections / irregularities / sharp edges (clauses 6.6 to 6.9)

All external projections other than press-fasteners are smooth and adequately faired, all external projections which are not more than 2 mm above the outer surface of the shell, have a radius of more than 1 mm, all external projections which are more than 2 mm above the outer surface of the shell have a radius of more than 2 mm.

All projections or irregularities in the outer surface of the shell which are higher than 2 mm, fulfill the requirements after the shear assessment test. The outer surface of the helmet fulfills the requirements after the friction assessment test.

There are no inward-facing sharp edges on the inside of the helmet; rigid, projecting internal parts are covered with padding so that any stresses transmitted to the head are not highly concentrated.

- fulfilled
- Not fulfilled
- n.a.

2.1.6 Test method for projections and surface friction

- Procedure A (7.4.1)
- Procedure B (7.4.2)

Helmet No.	Helmet Size (cm)	Condition	Projections	Friction
M-3	58	Solvent plus ambient temperature and hygrometry conditioning	Pass	Pass

2.1.7 Peripheral vision (clause 6.14)

Horizontal ($\geq 105^\circ$):

- fulfilled
- Not fulfilled
- n.a.

Upwards ($\geq 7^\circ$):

- fulfilled
- Not fulfilled
- n.a.

Downwards ($\geq 45^\circ$):

- fulfilled
- Not fulfilled
- n.a.

2.1.8 Conspicuity marking
(clause 6.16)

- fulfilled
- Not fulfilled
- n.a.

2.1.9 Impact-absorption tests
(clause 7.3)

x	fulfilled
	Not fulfilled
	n.a.

Size: 61 cm

Test Head Form: M (60 cm)

Helmet No.	Condition	Test anvil	Test site	Velocity (m/s)	Peak 'G ≤275g	HIC ≤2400
XXL-1	Solvent plus ambient temperature and hygrometry conditioning	Kerbstone	B	7.54	249.5	1525
		Kerbstone	X	7.60	194.1	1342
		Flat	P	7.57	239.4	2112
		Flat	R	7.53	224.1	2047
XXL-2	Solvent plus ambient temperature and hygrometry conditioning	Flat	B	7.56	210.5	1863
		Flat	X	7.52	265.9	2240
		Kerbstone	P	7.51	214.5	1590
		Kerbstone	R	7.57	187.2	1462
XXL-3	Solvent plus heat conditioning	Kerbstone	B	7.58	203.6	1619
		Kerbstone	X	7.58	168.1	1164
		Kerbstone	P	7.50	201.4	1834
		Kerbstone	R	7.58	159.5	1345
XXL-4	Solvent plus low temperature conditioning	Flat	B	7.58	210.9	1845
		Flat	X	7.61	240.8	2048
		Flat	P	7.50	220.0	2027
		Flat	R	7.59	222.0	2089
XXL-5	Solvent plus ultra-violet radiation conditioning and moisture conditioning	Kerbstone	B	7.53	211.3	1637
		Kerbstone	X	7.60	161.2	1201
		Flat	P	7.59	196.7	1922
		Flat	R	7.53	241.2	2083

Size: 54 cm

Test Head Form: E (54 cm)

Helmet No.	Condition	Test anvil	Test site	Velocity (m/s)	Peak 'G ≤ 275g	HIC ≤ 2400
XS-1	Solvent plus heat conditioning	Kerbstone	B	7.59	195.9	1220
		Kerbstone	X	7.57	178.0	1346
		Kerbstone	P	7.51	151.7	1136
		Kerbstone	R	7.58	174.5	1378
XS-2	Solvent plus low temperature conditioning	Flat	B	7.57	207.5	1431
		Flat	X	7.59	238.1	2321
		Flat	P	7.53	215.6	2253
		Flat	R	7.60	226.2	2079

Size: 58 cm

Test Head Form: J (57 cm)

Helmet No.	Condition	Test anvil	Test site	Velocity (m/s)	Peak 'G ≤ 275g	HIC ≤ 2400
M-1	Solvent plus heat conditioning	Kerbstone	B	7.60	240.4	1476
		Kerbstone	X	7.51	218.5	1390
		Kerbstone	P	7.61	269.1	1791
		Kerbstone	R	7.55	182.2	1464
M-2	Solvent plus low temperature conditioning	Flat	B	7.52	227.7	1901
		Flat	X	7.53	255.1	2151
		Flat	P	7.55	212.6	1947
		Flat	R	7.66	224.0	2283

2.1.10 Rigidity test (clause 7.5)

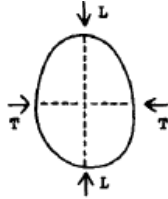

- fulfilled
- Not fulfilled
- n.a.

Helmet No.	Size	Condition	Direction	Max. deformation (≤ 40 mm)	Residual deformation (≤ 15 mm)
XXL-6	61	Solvent plus ambient temperature and hygrometry conditioning	Longitudinal axis	15.2	2.5
XXL-7	61	Solvent plus ambient temperature and hygrometry conditioning	Transverse axis	13.3	2.3

2.2 Retention system

2.2.1 The retention system is protected from abrasion

- fulfilled
- Not fulfilled
- n.a.

2.2.2 Chin strap (clause 6.11.1, 6.11.2)

The width of the chin strap is more than 20 mm under load of 150 N and it doesn't include a chin-cup.

- fulfilled
- Not fulfilled
- n.a.

2.2.3 Adjustment device (clause 6.11.3)

The retention system includes a device to adjust and maintain tension.

- fulfilled
- Not fulfilled
- n.a.

2.2.4 Fastening devices (clauses 6.11.4 to 6.11.9) The requirements for fastening devices and release mechanisms are in accordance to the requirements of the test standard.

- fulfilled
- Not fulfilled
- n.a.

2.2.5 Retention system dynamic test (clause 7.6)

- fulfilled
- Not fulfilled
- n.a.

Helmet No.	Helmet Size (cm)	Condition	Dynamic displacement (≤ 35 mm)	Residual displacement (≤ 25 mm)
XS-3 With type 1 retention system	54	Solvent plus ambient temperature and hygrometry conditioning	27.6	17.0
XS-4 With type 2 retention system	54	Solvent plus ambient temperature and hygrometry conditioning	28.3	17.9

2.2.6 Retention (detaching) test (clause 7.7)

- fulfilled
- Not fulfilled
- n.a.

Helmet No.	Helmet Size (cm)	Condition	Movement of the reference line (≤ 30°)
XS-3 With type 1 retention system	54	Solvent plus ambient temperature and hygrometry conditioning	23°
XS-4 With type 2 retention system	54	Solvent plus ambient temperature and hygrometry conditioning	22°

2.2.7	Micro-slip test of the chin strap (clause 7.9)	<input checked="" type="checkbox"/> fulfilled <input type="checkbox"/> Not fulfilled <input type="checkbox"/> n.a.
	Slippage of chin strap: (\leq 10mm):	<u><10</u> mm
2.2.8	Chin strap, resistance to abrasion test (clause 7.10)	<input checked="" type="checkbox"/> fulfilled <input type="checkbox"/> Not fulfilled <input type="checkbox"/> n.a.
2.2.8.1	Chin strap, withstand a tension of 3 kN (clause 7.10.5)	<input checked="" type="checkbox"/> fulfilled <input type="checkbox"/> Not fulfilled <input type="checkbox"/> n.a.
2.2.9	Retention systems relying on quick-release mechanisms (clause 7.11)	
2.2.9.1	Inadvertent release by pressure (clause 7.11.1)	<input type="checkbox"/> fulfilled <input type="checkbox"/> Not fulfilled <input checked="" type="checkbox"/> n.a.
2.2.9.2	Ease of release (clause 7.11.2)	<input type="checkbox"/> fulfilled <input type="checkbox"/> Not fulfilled <input checked="" type="checkbox"/> n.a.
2.2.9.3	Durability of quick-release mechanisms (clause 7.11.3)	<input type="checkbox"/> fulfilled <input type="checkbox"/> Not fulfilled <input checked="" type="checkbox"/> n.a.
2.3	Visor	<input type="checkbox"/> n.a. (no visor) <input checked="" type="checkbox"/> n.a. (visor separately approved)

Refer to approval no.: E1 22R 05300600

2.4 Information for wearers
(clauses 14.1 to 14.6)

2.4.1 Every protective helmet placed on the market shall bear a clearly visible label with the following inscription in the national language, or at least one of the national languages, of the country of destination:

<input checked="" type="checkbox"/>	fulfilled
<input type="checkbox"/>	Not fulfilled
<input type="checkbox"/>	n.a.

"For adequate protection, this helmet must fit closely and be securely attached. Any helmet that has sustained a violent impact should be replaced"

and, if fitted with a non protective lower face cover:

<input type="checkbox"/>	fulfilled
<input type="checkbox"/>	Not fulfilled
<input checked="" type="checkbox"/>	n.a.

"Does not protect chin from impacts"

together with the symbol indicating the unsuitability of the lower face cover to offer any protection against impacts to the chin

2.4.2 and, if hydrocarbons, cleaning fluids, paints, transfers or other extraneous additions affect the shell material adversely

<input checked="" type="checkbox"/>	fulfilled
<input type="checkbox"/>	Not fulfilled
<input type="checkbox"/>	n.a.

"'Warning' - Do not apply paint, stickers, petrol or other solvents to this helmet"

2.4.3 Every protective helmet shall be clearly marked with its size and its maximum weight, to the nearest 50 grammes, as placed on the market. The maximum weight quoted should include all the accessories that are supplied with the helmets, within the packaging, as it is placed on the market, whether or not those accessories have actually been fitted to the helmet.

<input checked="" type="checkbox"/>	fulfilled
<input type="checkbox"/>	Not fulfilled
<input type="checkbox"/>	n.a.

2.4.4 Every protective helmet offered for sale shall bear a label showing the type or types of visor that have been approved at the manufacturer's request.

<input checked="" type="checkbox"/>	fulfilled
<input type="checkbox"/>	Not fulfilled
<input type="checkbox"/>	n.a.

2.4.5 Every visor offered for sale shall bear a label showing the types of protective helmet for which it has been approved

<input checked="" type="checkbox"/>	fulfilled
<input type="checkbox"/>	Not fulfilled
<input type="checkbox"/>	n.a.

2.4.6 Every visor placed on the market with a protective helmet shall be accompanied by information in the national language, or in at least one of the national languages, of the country of destination. This information shall contain:

2.4.6.1 General Instruction for Storage and Care

<input checked="" type="checkbox"/>	fulfilled
<input type="checkbox"/>	Not fulfilled
<input type="checkbox"/>	n.a.

2.4.6.2 Specific instructions for cleaning and their notice of use. These instructions shall include a warning regarding the dangers of using unsuitable agents for cleaning (such as solvents), especially if abrasion resistant coatings are to be preserved.

<input checked="" type="checkbox"/>	fulfilled
<input type="checkbox"/>	Not fulfilled
<input type="checkbox"/>	n.a.

2.4.6.3 Advice as to the suitability of the visor for use in conditions of poor visibility and during the hours of darkness. The following warning shall be included: Visors with the marking indicating "daytime use only" are not suitable for use during the hours of darkness or in conditions of poor visibility.

<input checked="" type="checkbox"/>	fulfilled
<input type="checkbox"/>	Not fulfilled
<input type="checkbox"/>	n.a.

2.4.6.4 If appropriate, the following warning shall also be included

The fastening of this visor is such that it will not be possible to remove it instantly from the line of sight with one hand should an emergency (such as headlamp glare or misting) occur.

	fulfilled
	Not fulfilled
x	n.a.

2.4.6.5 If the visor is MIST RETARDANT approved it may be indicated

	fulfilled
	Not fulfilled
x	n.a.

2.4.6.6 Instructions regarding the detention of obsolescence

x	fulfilled
	Not fulfilled
	n.a.

3 Other information

Place of testing: SGS CSTC Guangzhou, P.R. China

Date of testing: From 07.06.2018 to 28.06.2018

4 Remarks: ---



List of modifications

- | | | |
|---|------------------|------|
| 1 | Correction of: | n.a. |
| 2 | Modification of: | n.a. |
| 3 | Addition of: | n.a. |
| 4 | Deletion of: | n.a. |

INFORMATION DOCUMENT

No.: R22-OF573-1-00



Jiangmen Pengcheng Helmets Co., Ltd.

TYPE: OF573-1

Protective helmet with visor
pursuant to

Regulation No. 22

UNIFORM PROVISIONS CONCERNING THE APPROVAL OF
PROTECTIVE HELMETS AND THEIR VISORS FOR DRIVERS AND
PASSENGERS OF MOTORCYCLES AND MOPEDS

Signature of a responsible person:

A handwritten signature in black ink, appearing to be 'J. Pengcheng', written over a horizontal line.

Date: 01.06.2018



Type : OF573-1
 Manufacture : Jiangmen Pengcheng Helmets Co., Ltd.

Date: 01.06.2018
 Page 2 of 15

0 GENERAL INFORMATION

- 0.1 Make (trade name of manufacturer) : LS2, MHR, TAKAI
- 0.2 Type : OF573-1
- 0.2.1 Commercial description(s) : OF573, OF573-1, TWISTER
- 0.3 Variants / Versions : n.a.
- 0.4 Name and address of manufacturer : Jiangmen Pengcheng Helmets Co., Ltd.
 Industrial Park East, Gonghe Town, Heshan City Guangdong Province, China
- 0.5 Name and address of assembly plant : Jiangmen Pengcheng Helmets Co., Ltd.
 Industrial Park East, Gonghe Town, Heshan City Guangdong Province, China
- 0.6 Name and address of manufacturer's authorized representative (if any) : n.a.
- 0.7 Location and method of affixing of the international approval mark : Marked in a label sewn on the retention system chin strap, see Annex 6

1 TECHNICAL DESCRIPTION

- 1.1 Description of the helmet
 - 1.1.1 Type of helmet : Open face
 - 1.1.2 Type of lower face cover : "J" none
 - 1.1.3 Size (s) : XS(54), S(56), M(58), L(59), XL(60), XXL(61)
 - 1.1.4 Drawing of the helmet : See annex 1
 - 1.1.5 Type(s) of visor to which may be equipped with this helmet : OF-MHR-88
- 1.2 Description of the visor : Visor type: OF-MHR-88
 Approval No.: E1 22R 05300600
- 1.3 Description of the shell
 - 1.3.1 Material : ABS
 - 1.3.2 Manufacture method : Injection
 - 1.3.3 Ventilation : See Annex 1
 - 1.3.4 Composition of the border join on the shell : PVC
 - 1.3.5 Drawing of the shell : See annex 3
- 1.4 Description of protective padding
 - 1.4.1 Composition : EPS
 - 1.4.2 Density and weight :

Size (cm)	Shell size	Comfort padding thickness (Main) (mm)	Protective padding Density (Main +Ears + Top) (Kg/m ³)	Protective padding Thickness (mm)	Protective padding Weight (Main +Ears + Top) (grams)
XS(54)	S-XS	12	50+50	30-35	98.2+30.6
S(56)	S-XS	12	50+50	30-35	98.2+30.6
M(58)	XXL-M	11	50+55	30-35	87.8+32.4
L(59)	XXL-M	10	50+55	30-35	87.8+32.4
XL(60)	XXL-M	10	60+75	30-35	109.1+42.2
XXL(61)	XXL-M	8	60+75	30-35	109.1+42.2

- 1.4.3 Drawing of the protective padding : See annex 4



Type : OF573-1
 Manufacture : Jiangmen Pengcheng Helmets Co., Ltd.

Date: 01.06.2018
 Page 3 of 15

- 1.5 Description of comfort padding
- 1.5.1 Composition of
 - Comfort padding : Compound sponge
 - Comfort tissue : Nylon
 - Protection of the back of the nape : Compound sponge, Compound cloth and leather
 - Lateral packing : EPS and compound sponge
 - Lower face cover : n.a.
- 1.5.2 Drawing of the comfort padding : See annex 5
- 1.6 Description of the retention system
- 1.6.1 Chin strap
 - Material : Nylon
 - Width : 22 mm or 25 mm
- 1.6.2 Retention system : Type 1: Double-D ring with 25mm Chin strap
 Type 2: No.17 quick release mechanism with 22mm Chin strap
- 1.6.3 Comfort padding of the retention system
 - Composition : Leather and textile
 - Thickness : 3 mm
- 1.6.4 Anchorage system to the shell : By means of a metallic piece fixed to the shell by rivets
- 1.6.5 Drawing of the retention system : See annex 6
- 1.7 Other Characteristics
- 1.7.1 Markings
 - Make : Rear part of the shell
 - Weight : Rear part of the shell
 - Size : Rear part of the shell
- 1.7.2 Indelible marking
 - How it is made : Sewing
 - Position : On the chin strap
- 1.8 Accessories
- 1.8.1 Peak : n.a.
- 1.8.2 Information for wearer
 - 1.8.2.1 Text : See annex 7
 - 1.8.2.2 Position : Hang on chin strap

ANNEXS

Annex 1	Drawing of the helmet	25.03.2018
Annex 2	Drawing of the sun shade	25.03.2018
Annex 3	Drawing of the shell	25.03.2018
Annex 4	Drawing of the protective padding	25.03.2018
Annex 5	Drawing of the comfort padding	25.03.2018
Annex 6	Drawing of the retention sys	25.03.2018
Annex 7	Information for wearer	25.03.2018



Type : OF573-1
 Manufacture : Jiangmen Pengcheng Helmets Co., Ltd.

Date: 01.06.2018
 Page 4 of 15

Annex 1: Drawing of the helmet

序号 number	名称 name	单位 unit	数量 piece	材料 material
1	壳体 Outer shell	个 piece	1	abs
2	泡沫 protective padding	个 piece	4	eps
3	内衬 comfort padding	套 set	1	nylon
4	快速扣/双平面快扣 buckle/Double "D" ring	套 set	1	stainless steel
5	帽带 chin strap	条 unit	2	nylon
6	镜片 visor	个 piece	2	pc
7	顶前风窗 top vent	个 piece	1	abs
8	后风窗 back vent	个 piece	1	abs

MODEL	OF573-1·XXL-M				OF573-1-S-XS			
SIZE	XXL	XL	L	M	S	XS		
CM	61	60	59	58	56	54		

技术要求
 Technical requirements

1. The surface of the outshell should be smooth and bright no mottle, pinhole, bulb, drop lack of oil, discolour of basic color.
 2. Every spare parts should be fixed correctly, and not be loose, missed.



Type : OF573-1
 Manufacture : Jiangmen Pengcheng Helmets Co., Ltd.

Date: 01.06.2018
 Page 5 of 15

Annex 2: Drawing of the sun shade

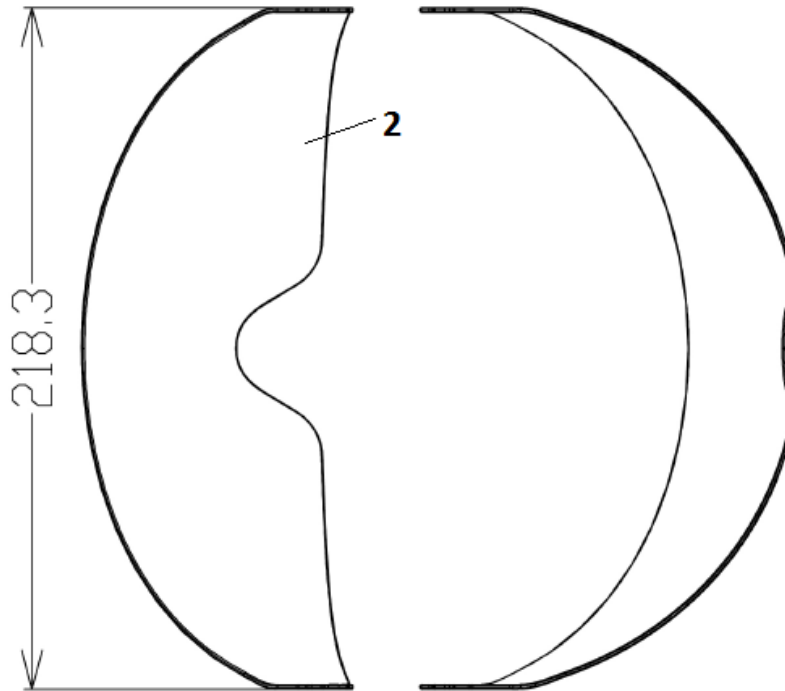
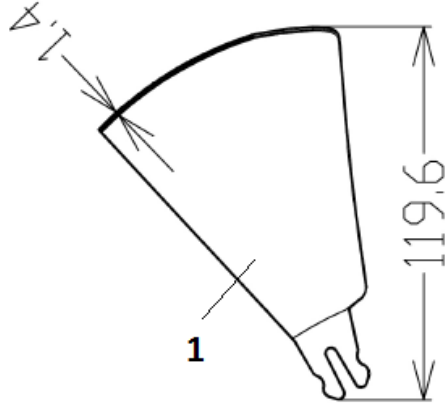

Unit: mm

Number	Name	Parameter	Number	Name	Parameter
1	Sun Shade Material	PC	2	Warning	DAYTIME USE ONLY
Description	OF573-1 Sun Shade		Code No.:	OF573-1.2	
Manufacturer:	Jiangmen Pengcheng Helmets Co., Ltd.				
Address:	Industrial Park East, Gonghe Town, Heshan City Guangdong Province, China				
Drawn by:	Xinsheng Liu	Checked by:	Xinsheng Liu	Approved by:	Youjun Feng
Date:	17.03.2018	Date:	20.03.2018	Date:	25.03.2018



Type : OF573-1
 Manufacture : Jiangmen Pengcheng Helmets Co., Ltd.

Date: 01.06.2018
 Page 6 of 15

Annex 3: Drawing of the shell

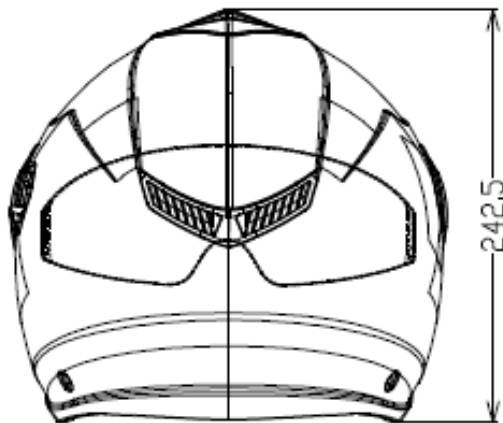
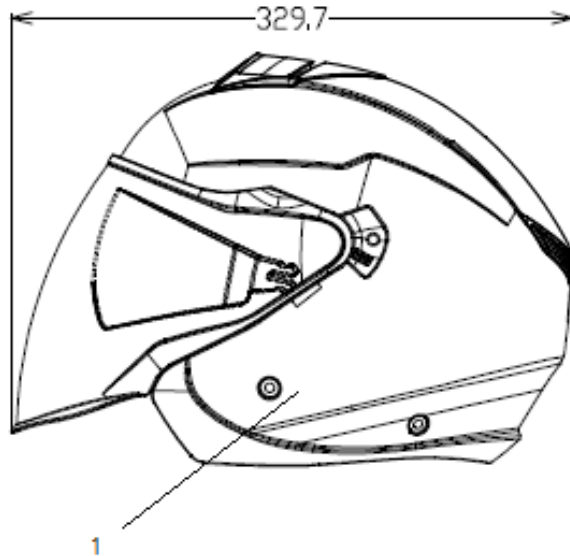
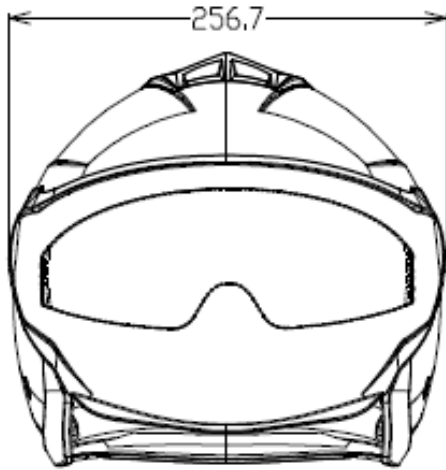

OF573-1 XXL-M

Unit: mm

Number	Name	Parameter	Number	Name	Parameter
1	Shell	ABS			
Description	OF573-1 XXL-M Shell		Code No.:	OF573-1.3.1	
Manufacturer:	Jiangmen Pengcheng Helmets Co., Ltd.				
Address:	Industrial Park East, Gonghe Town, Heshan City Guangdong Province, China				
Drawn by:	Xinsheng Liu	Checked by:	Xinsheng Liu	Approved by:	Youjun Feng
Date:	17.03.2018	Date:	20.03.2018	Date:	25.03.2018

INFORMATION DOCUMENT

R22-OF573-1-00



Type : OF573-1
 Manufacture : Jiangmen Pengcheng Helmets Co., Ltd.

Date: 01.06.2018
 Page 7 of 15

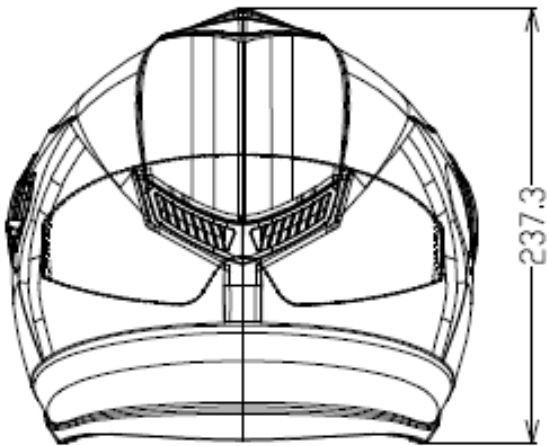
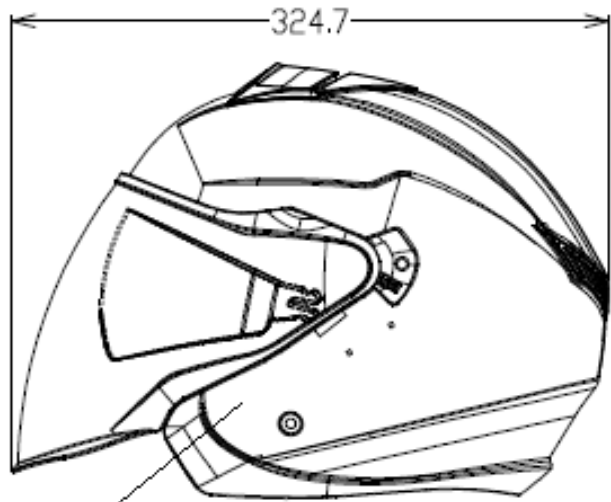
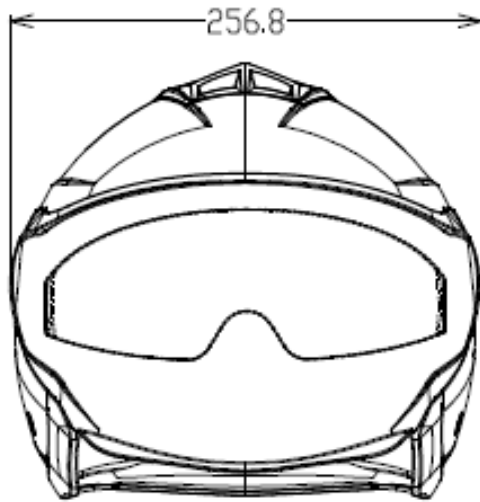

OF573-1-S-XS

Unit: mm

Number	Name	Parameter	Number	Name	Parameter
1	Shell	ABS			
Description	OF573-1 S-XS Shell		Code No.:	OF573-1.3.2	
Manufacturer:	Jiangmen Pengcheng Helmets Co., Ltd.				
Address:	Industrial Park East, Gonghe Town, Heshan City Guangdong Province, China				
Drawn by:	Xinsheng Liu	Checked by:	Xinsheng Liu	Approved by:	Youjun Feng
Date:	17.03.2018	Date:	20.03.2018	Date:	25.03.2018



Type : OF573-1
 Manufacture : Jiangmen Pengcheng Helmets Co., Ltd.

Date: 01.06.2018
 Page 8 of 15

Annex 4: Drawing of the protective padding

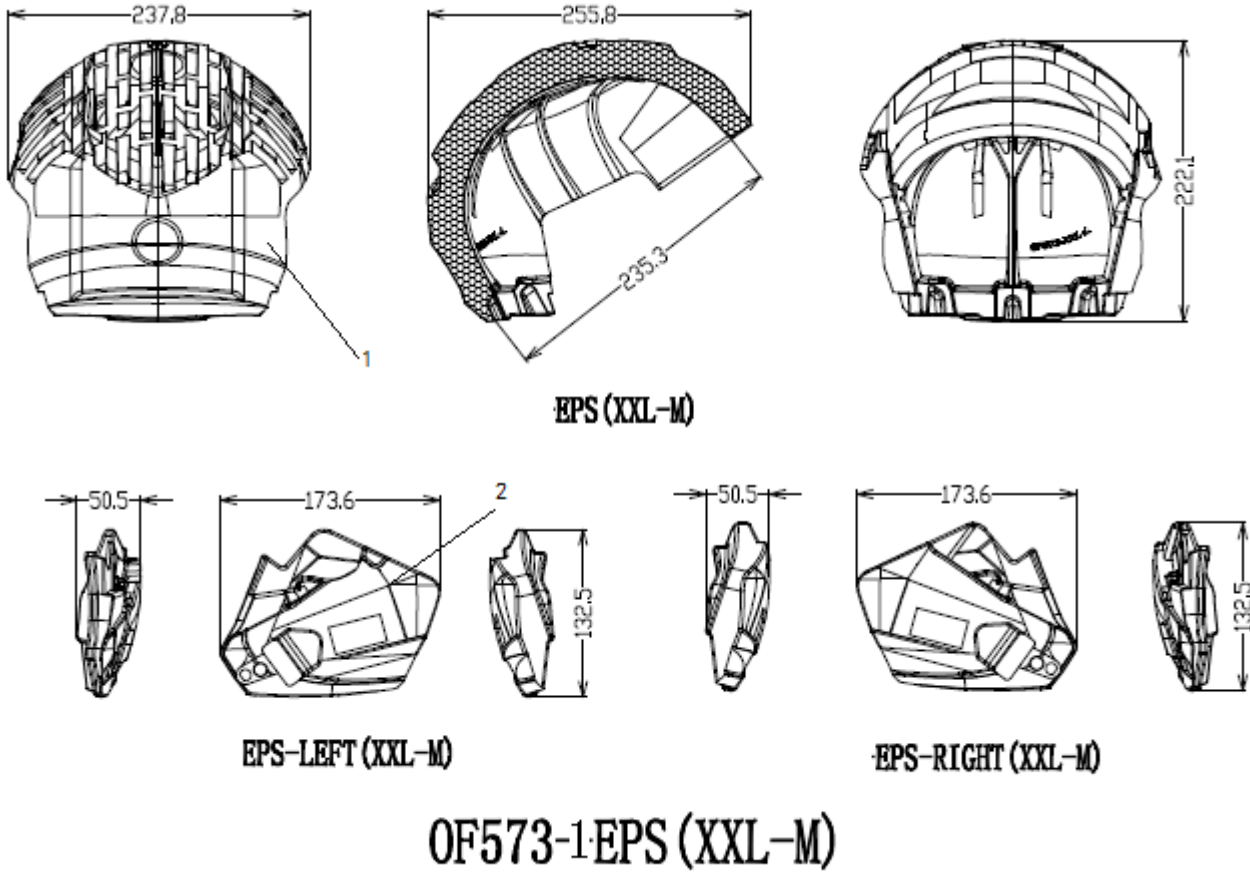

Unit: mm

Number	Name	Parameter	Number	Name	Parameter
1	Main protective padding	EPS	2	Ear protective padding	EPS
Description	OF573-1 XXL-M Protective padding		Code No.:	OF573-1.4.1	
Manufacturer:	Jiangmen Pengcheng Helmets Co., Ltd.				
Address:	Industrial Park East, Gonghe Town, Heshan City Guangdong Province, China				
Drawn by:	Xinsheng Liu	Checked by:	Xinsheng Liu	Approved by:	Youjun Feng
Date:	17.03.2018	Date:	20.03.2018	Date:	25.03.2018



Type : OF573-1
 Manufacture : Jiangmen Pengcheng Helmets Co., Ltd.

Date: 01.06.2018
 Page 9 of 15

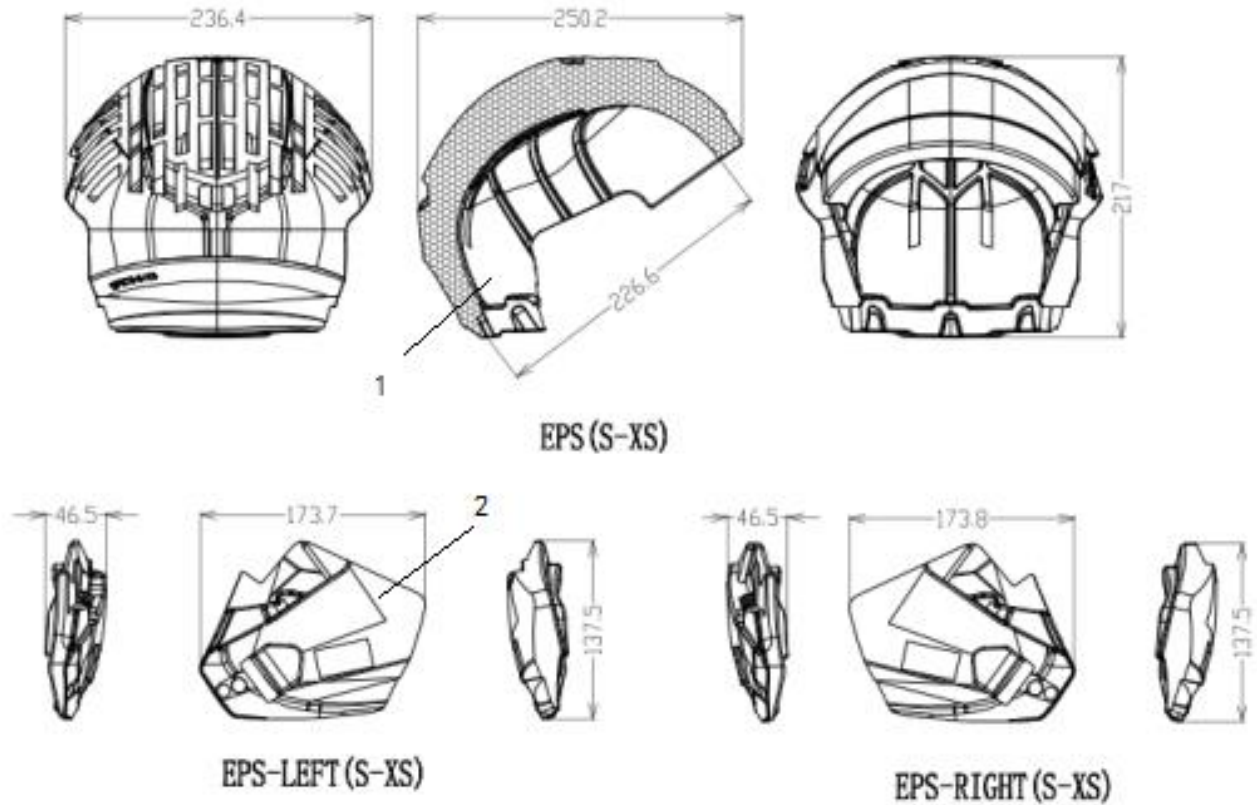

OF573-1 EPS (S-XS)

Unit: mm

Number	Name	Parameter	Number	Name	Parameter
1	Main protective padding	EPS	2	Ear protective padding	EPS
Description	OF573-1 S-XS Protective padding		Code No.:	OF573-1.4.2	
Manufacturer:	Jiangmen Pengcheng Helmets Co., Ltd.				
Address:	Industrial Park East, Gonghe Town, Heshan City Guangdong Province, China				
Drawn by:	Xinsheng Liu	Checked by:	Xinsheng Liu	Approved by:	Youjun Feng
Date:	17.03.2018	Date:	20.03.2018	Date:	25.03.2018



Type : OF573-1
 Manufacture : Jiangmen Pengcheng Helmets Co., Ltd.

Date: 01.06.2018
 Page 10 of 15

Annex 5: Drawing of the comfort padding

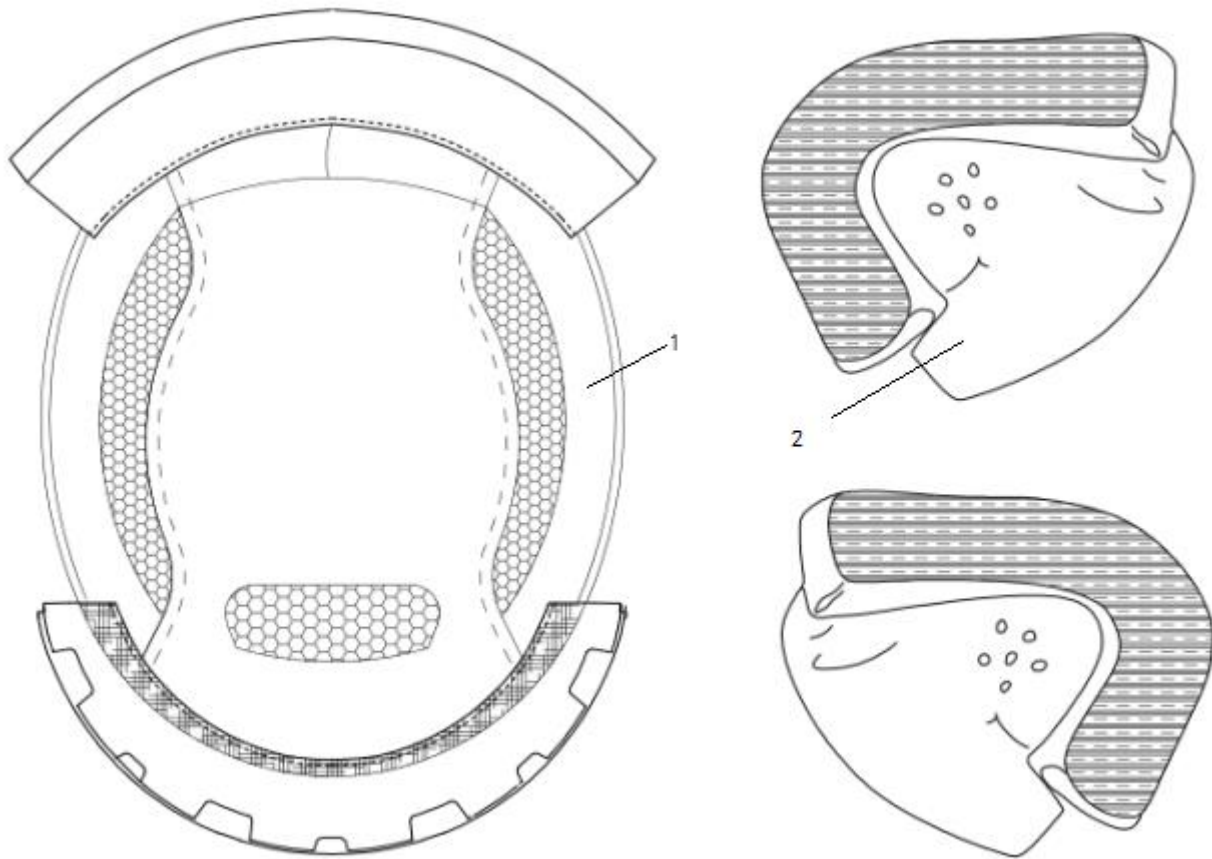

Number	Name	Material	Number	Name	Material
1	Comfort padding	Compound sponge + Cloth	2	Ear Comfort padding	Compound sponge + Cloth + PP
Description	OF573-1 Comfort padding		Code No.:	OF573-1.5	
Manufacturer:	Jiangmen Pengcheng Helmets Co., Ltd.				
Address:	Industrial Park East, Gonghe Town, Heshan City Guangdong Province, China				
Drawn by:	Xinsheng Liu	Checked by:	Xinsheng Liu	Approved by:	Youjun Feng
Date:	17.03.2018	Date:	20.03.2018	Date:	25.03.2018



Type : OF573-1
 Manufacture : Jiangmen Pengcheng Helmets Co., Ltd.

Date: 01.06.2018
 Page 11 of 15

Annex 6: Drawing of the retention system

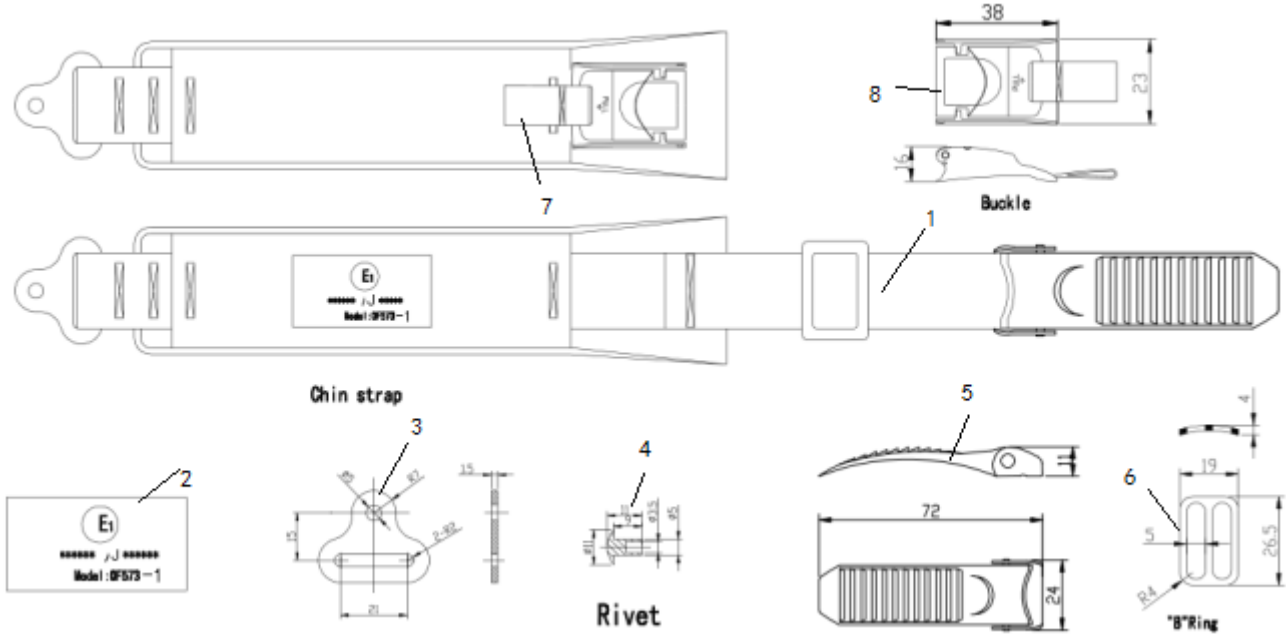

Unit: mm

Number	Name	Material	Number	Name	Material
1	Chin strap	Nylon	5	Slider bar	Polycarbonate + Steel
2	ECE Marking	Cloth	6	"B" Ring	Nylon
3	Hinge	Steel	7	Red small strap	Nylon
4	Rivet	Steel	8	Quick release buckle	Polycarbonate + Steel
Description	OF573-1 Retention system (17 Buckle)		Code No.:	OF573-1.6.1	
Manufacturer:	Jiangmen Pengcheng Helmets Co., Ltd.				
Address:	Industrial Park East, Gonghe Town, Heshan City Guangdong Province, China				
Drawn by:	Xinsheng Liu	Checked by:	Xinsheng Liu	Approved by:	Youjun Feng
Date:	17.03.2018	Date:	20.03.2018	Date:	25.03.2018

INFORMATION DOCUMENT

R22-OF573-1-00



Type : OF573-1
 Manufacture : Jiangmen Pengcheng Helmets Co., Ltd.

Date: 01.06.2018
 Page 12 of 15

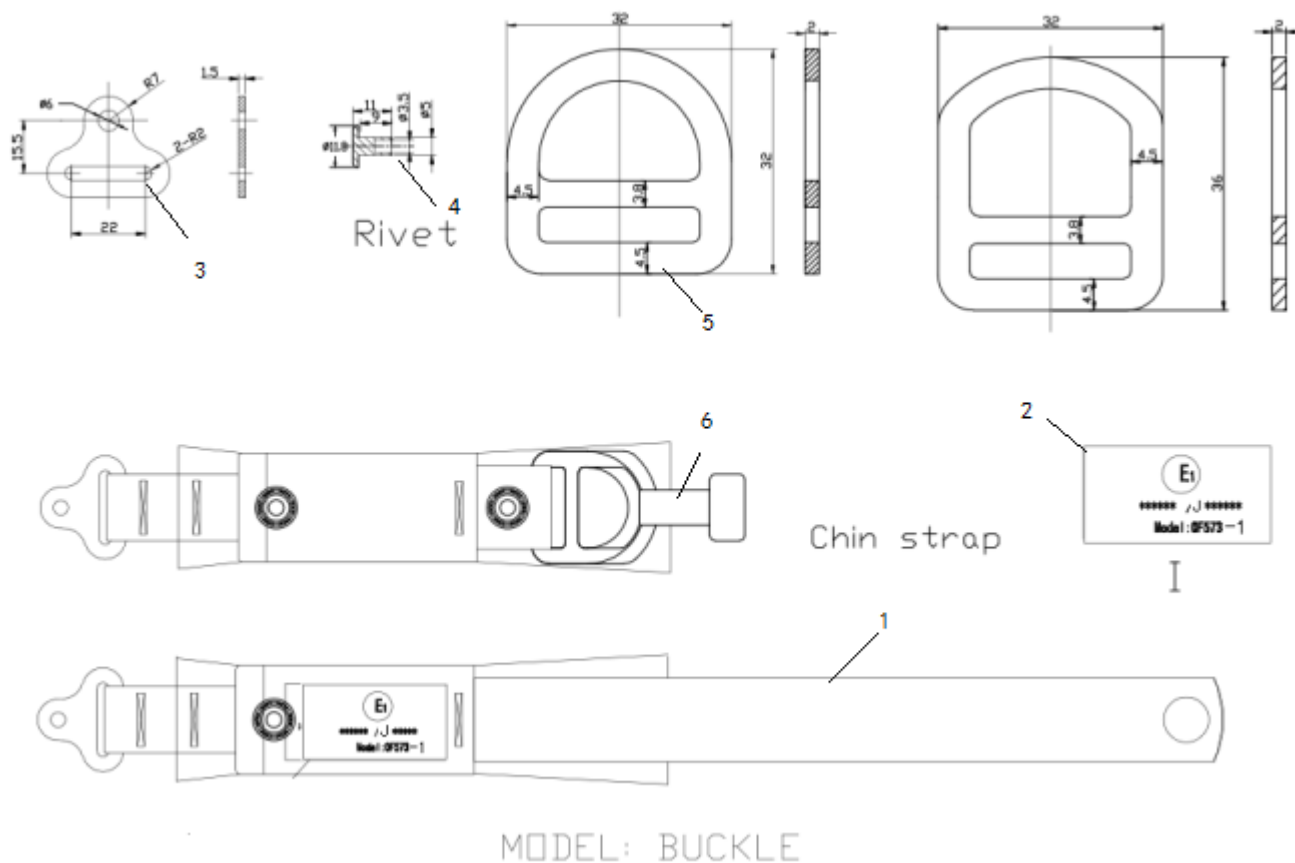

Unit: mm

Number	Name	Material	Number	Name	Material
1	Chin strap	Nylon	4	Rivet	Steel
2	ECE Marking	Cloth	5	"D" Ring	Steel
3	Hinge	Steel	6	Red small strap	Nylon
Description	OF573-1 Retention system (Double "D" Ring)		Code No.:	OF573-1.6.2	
Manufacturer:	Jiangmen Pengcheng Helmets Co., Ltd.				
Address:	Industrial Park East, Gonghe Town, Heshan City Guangdong Province, China				
Drawn by:	Xinsheng Liu	Checked by:	Xinsheng Liu	Approved by:	Youjun Feng
Date:	17.03.2018	Date:	20.03.2018	Date:	25.03.2018



Type : OF573-1
 Manufacture : Jiangmen Pengcheng Helmets Co., Ltd.

Date: 01.06.2018
 Page 13 of 15

Annex 7: Information for wearer

Congratulations on purchasing your new **LS2** helmet. Please read these instructions carefully before use. They contain valuable informations to help you obtain the most protection from your helmet and to ensure a longer life for your helmet. All our products come from the most advanced research in terms of active security and design. The very high level for aerodynamism and comfort will get you the best performances all along the road. Whatever can be your choice leisure, tourism, racing, one of the helmets from the LS2 range is the best solution for your active protection.

1. Read these instructions thoroughly before using your helmet for the first time and store them safely for future reference.
2. A helmet like all products may wear out over time depending upon its use and the amount of care that is given. Please check your helmet every time before use for damage and do not use a damaged helmet. The most known standards of homologation recommend a helmet life of five years. LS2 agrees with their recommendation even though your helmet does not show any signs of malfunction, visible damage or defect. We strongly recommend you replace your helmet five years after the original date of purchase. See also "ONE IMPACT RULE" of item 3 in this manual, which says clearly "helmet is designed to help absorb one impact".
3. If you have any questions or comments concerning this helmet, please contact your nearest LS2 dealer or agent. Note that these specifications are subject to change without notice, as we continually strive to improve our products.

HOW TO CHOOSE A HELMET AND WEAR IT CORRECTLY

No helmet can protect the wearer against all foreseeable high speed and low speed impact. however, for maximum head protection the helmet must be of proper fit and the retention system must be securely fastened under the chin. Failure to have proper fit and to securely fasten the helmet is dangerous as the helmet could come off in an accident resulting in severe head injury or death.

1 To determinate proper fit.

- 1.1. Measure your head size. Wrap a tape measure horizontally around your head at the height of about 2,5 cm above your eyebrows. This will establish the longest measurement around your head.
- 1.2. Select the helmet that is the closest match to your head size. If your head size should fit between two helmet sizes, try on the smaller one first.

2 Try the helmet on

- 2.1. Expand the helmet opening by the straps, and slide your head into the helmet. Pull the chin straps only, not the chin straps cover, pulling on the covers may rip them. If the helmet is not tight, it is too big for you. If you are unfamiliar with helmets you may be reluctant to pull down the helmet which should feel tight. Even if you feel it is difficult to put it on, please use the smallest helmet possible.

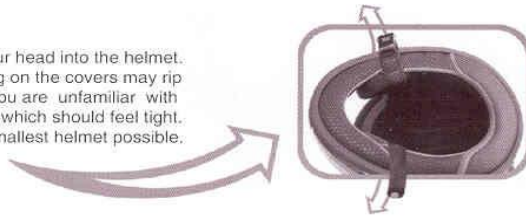

3 Check for a proper fit. With the helmet, go through the following checklist to determine whether the helmet is the correct size.

- 3.1. Make sure the inner lining fits snugly all around your head.
- 3.2. Make sure the top pad presses closely to the top of your head.
- 3.3. Check whether the cheek pads are in contact with your cheeks.
- 3.4. Make sure there is no space between inner lining and brow where you could insert your finger.
- 3.5. Now, take hold of the helmet with a hand on each side. Without moving your head, try to move the helmet up and down, and side to side. You should feel the skin of your head and face being pulled as you try to move the helmet. If you can move the helmet around easily, it is too big. Try a smaller size.



4 Check the retention system and go through the following steps.

- 4.1. Fasten the chinstrap as tight as possible without causing you pain (see diagram 2). There must be no slack in the strap and it must be tight up against your chin.
- 4.2. With the chinstrap secured, put your hands flat on the back of the helmet and try to push the helmet off by rotating forward.
- 4.3. Next, put your hands on the front of the helmet above your forehead (or on the chinguard) and try to push the helmet off by rotating it toward the rear.
- 4.4. If the helmet starts to come off in either direction, do not use the helmet, either the helmet is too large for you or the chin strap is not tightened enough.

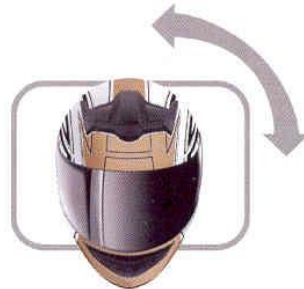

ENGLISH

Tightening the chinstrap correctly is extremely important. Try to pull down on the chinstrap with the tips of your fingers if the strap is not against your chin or loosens, you have not properly put the strap through the D rings. Start again (see diagram 2) If your chinstrap is loose, the shock of an impact may knock your helmet off, leaving your head completely unprotected. Do not use a helmet that can be rolled off the head with the chinstrap fastened, since it may come off in an accident, resulting in death or serious personal injuries.



Type : OF573-1
 Manufacture : Jiangmen Pengcheng Helmets Co., Ltd.

Date: 01.06.2018
 Page 14 of 15

D RING: To securely fasten the D ring retention system, thread the end of the chinstrap through the D rings only as shown in diagram 2 and put it tight against your throat. Clip the chin strap end hook on the D ring as shown in diagram 2 to secure the loose end of the chin strap after it's securely fastening the chin strap. The only function of the chinstrap end hook fitted on the end of the chinstrap is to avoid fluttering of the end part of the chinstrap.

Quick-release retention system: To fasten the strap, push the metal tongue firmly into the buckle until it locks with a click. Pull the strap tight and pass the end of the strap through the strap ring or ladder to secure it. To release the strap, press the two catches inward (or slide the catches down).

SAFETY RECOMMENDATIONS

1

No helmet can protect wearer against all foreseeable high speed and low speed impacts.

However, for maximum head protection, the helmet must be of proper fit and retention system must be securely fastened under the chin. The helmet should allow peripheral vision when secure on your head. If your helmet is too large, it may sleep or move on your head while riding which may make it possible for your helmet to come off in an accident or to obstruct your vision while riding. In the first case, your helmet will not protect your head in an accident, which can result in serious personal injury or death and in the second case, if you cannot see you may have an accident.

2

Use only a helmet that fits snugly all around your head, and fasten the chinstrap securely under your chin.

Expand the helmet opening with your hands, and slide your head into the helmet. Please check whether the helmet fits properly according to the checklist (paragraph 3, page 3). Pull the chinstraps only, not the chinstraps covers. Pulling on the covers may rip them; if the helmet is not tight, it is too big for you, to securely fasten the D ring retention system, thread the end of the chinstrap through the D rings only as shown, and pull it tight up against your throat. In the case of quick-release retention system, refer to upper paragraph. If your chinstrap is loose, the shock of an impact may knock your helmet off leaving your head completely unprotected resulting in serious personal injury or death.

3

Helmets are designed to help absorb ONE impact. After your helmet has protected you from an impact, you must get a new one.

Your helmet is designed to distribute the force incurred during an impact over a wide area. Even if your helmet looks undamaged externally its useful life is finished after one impact during riding, for example, a capsized or accident where you and your helmet hit the ground or some object. In an impact, the helmet's impact absorbing liner becomes compacted. Once this has happened, the helmet no longer has the ability to absorb further impacts. Your helmet may look the same, but it will not provide protection in an accident, if you have any doubts, for example, if you drop your helmet or if it is hit by something and you are not sure if this one impact rule applies, consult your LS2 dealer before you use the helmet again.



4

Clean your helmet carefully.

Never use hot or salt water, benzene, gasoline, glass cleaner or other solvents. Your helmet could be seriously damaged by these substances, without showing any apparent visible damage. A helmet damaged or weakened by a cleaning agent may not provide head protection in an accident resulting in serious personal injury or death. The correct way to clean a helmet is to mix 5 or 6 drops of mild soap in a quart of warm water. Dampen a soft cloth with this solution and wipe the helmet clean. Rinse with a wet cloth.

5

Never modify your helmet.

It is very dangerous to drill holes or cut the shell and/or the shock absorber liner. Modifications can seriously weaken the helmet. Modifying the retention system weakens it, and it may snap in an impact, removing parts such as the mouth guard or rubber face trim can expose edges, which may injure you in an accident. Always use approved LS2 parts when replacing shields, screws, or any other parts. A weakened helmet will not provide protection.

6

Don't mistreat your helmet.

Never ride with the helmet hanging from the helmet holder, and don't hang the helmet from angled supports like a mirror. Don't sit on your helmet or throw it around. You should not expose the liner of your helmet to strong sunlight and excessive heat such as near heaters or where temperatures exceed 50° C (122 F). Avoid the spray of insect repellent chemicals (such as "naphthalene") near the helmet. Mistreating your helmet will damage the shell and impact absorbing liner and reduce the helmet's ability to protect you in an accident.

7

Always check your helmet before riding off.

1. Check the shield and visor screws, and retighten them if necessary.
2. Check for cracks in the helmet. Strong acid (for example, battery acid) can damage the shield base. If you find cracks or damage, stop using the helmet immediately.
3. Plastic components may start to wear out about 5 years after manufacture. If you find deterioration in any part of a component, either replace that component or get a new helmet. If these parts come loose and/or fall off while you are riding, your vision may be blocked which could cause an accident resulting in serious personal injury or death.
4. Check the security of the retention system
5. Make sure that the center pad (or comfort liner) and the cheek pads are attached before you use the helmet.

ENGLISH



Type : OF573-1
 Manufacture : Jiangmen Pengcheng Helmets Co., Ltd.

Date: 01.06.2018
 Page 15 of 15

8

Maintain your helmet shield in good condition.

If your shield becomes too scratched or undeanable, replace it with a new one. Impaired visibility causes accidents. Clean your shield with mild soapy water, rinse well with clean water, and dry with a soft cloth. Never use benzene gasoline, glass cleaner or any other solvents. Do not attach stickers or adhesive tape to the shield, as this will weaken the hard coating. This can damage the shield. Do not drive with a dim or blurred face shield. Impaired vision can cause an accident resulting in serious personal injury or death.

9

Do not repaint the helmet.

We do not recommend you repaint the helmet, because paint and thinner can damage the materials used in the helmet construction. A helmet damaged weakened by a paint agent may not provide head protection in an accident resulting in serious personal injury or death. If you must paint your helmet, please consult your LS2 dealer.

10

Remember: helmets block important sounds and reduce awareness of environmental changes.

When you wear a helmet, especially a full-face type, you are somewhat isolated from the environment around you. Weather changes can catch you unprepared: sudden showers or temperature variations as you enter or leave tunnels or climb mountain roads can cause unexpected misting of your shield and loss of visibility. Do not drive with a fogged face shield. Wearing a helmet also reduces your ability to hear traffic sounds, especially of high speed. With a full face helmet, opening and closing the shield makes a major difference in how much you can hear. For safe riding be aware of how your helmet type, your speed, affects your perception of road conditions and whether your shield is open.

11

Warning: the sun shade should be used accompany with the protective visor. Do not use the sun shade only

